

REVISION HISTORY				
REV	DATE	DESCRIPTION	BY	CHKD
4	05/10/2017	TECTITES NOT SUPPLIED	PH	RD

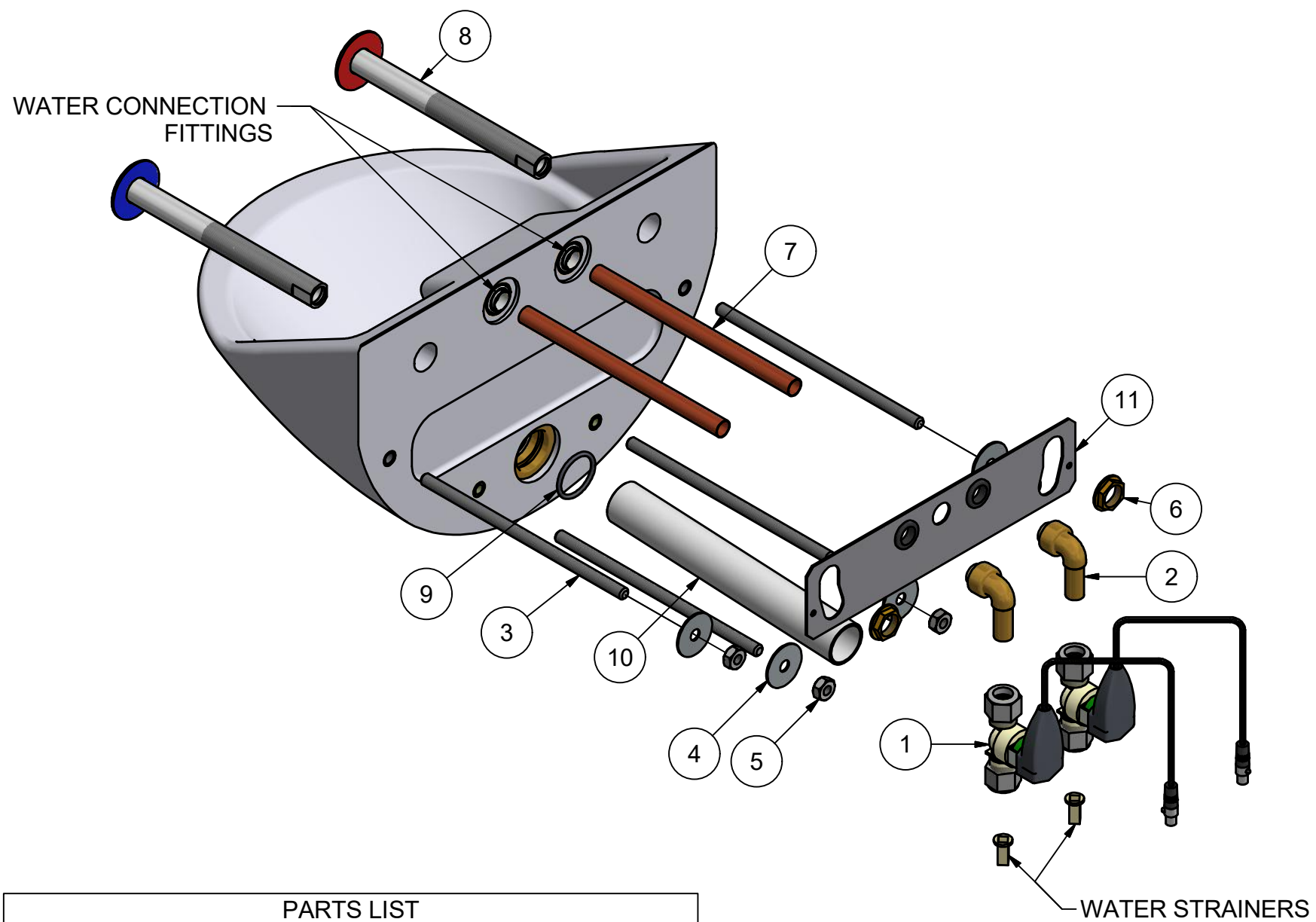

Assembly details:

Refer to the basin product manual for full installation details.

1. Fit the basin wall fixing studs (Item 3) to the threaded inserts on the basin back. Ensure each stud screws in by a minimum of 35mm & tighten to 6Nm.
 2. Fit the copper water tubes (Item 7) into the water connection fittings in the rear of the basin. The copper water tubes are a push fit into the connectors. Ensure that the end of each copper tube is free of sharp burrs & is free of any visible damage such as being deformed, dented or heavily scratched which may result in a failure of the water seal. The copper water tube must be inserted into the connector to a depth of 23.5mm.
 3. Fit the waste pipe to the basin waste outlet socket. The socket is fitted with an O ring seal. Prior to fitting the pipe, ensure the pipe end is free of burrs & is slightly chamfered & moisten/lubricate the pipe end or the O ring seal to ease the fit of the pipe which is a push fit into the socket. The pipe must push in by 20mm & should be angled downwards by 3° to give a fall for water drainage.
 4. The two piezo touch buttons or IR sensors (Item 8) can be passed into the two apertures on the basin splash back with the one with the blue cold water bezel located on the right hand aperture as from the front of the basin. **HANDLE CABLES WITH CARE.**
 5. Mount the basin onto the wall taking care to avoid damage to the copper tubes, button/sensor cables & the waste pipe as they pass through the wall. Fit the nuts & washers onto the wall fixing studs & hand tighten only.
 6. Place the wall plate (Item 11) over the button/sensor tubes & the two copper water tubes. Fit the flange nuts (Item 6) to the button/sensor tubes and hand tighten only.
 7. Check the position of the basin to ensure it is level in all three planes & to ensure it is not being supported by resting on the water tubes. Fully tighten each wall fixing in a diagonal sequence to 17Nm.
 9. Tighten the button/sensor tube nuts to 17Nm using a spanner to grasp the flats on the tube.
 10. The water valve & cable pack (Item 1) are supplied as a separate sales item (ie; P/No WVPB400-2). Assemble the valves to the copper water tubes (Item 10) referring to the instruction drawing supplied with the water valve pack. Note that the push fit elbow fittings (Item 2) are not supplied with the water valve pack or basin.
 11. Connect the water supply feeds to each water valve (Item 1) ensuring that the water strainers supplied with each valve are located into the end of the supply pipes (15mm copper tube) before assembly into each water valve. The compression nut on each valve should be tightened to 4Nm.
- Note: A means of controlling the hot water temperature is required, such as a TMV3 valve. The electronic basin controls do not control water temperature.**
12. Connect a deep seal waste trap to the waste supply pipe and then to the basin waste pipe (Size 1 1/4" / 32mm). Note that that the waste trap should be positioned below the level of the basin waste outlet to provide a good drainage flow rate.
 13. Connect the water valve cables & piezo touch button or infra red sensor cables to the electronic control unit by referring to the product manual for the control unit.
 14. Seal the edges of the basin to the wall using anti-pick hard set mastic such as Arbokol 1025 or Sikadur 33.
 15. Carry out final commissioning of the product to ensure its correct operation and set up. Further details are available in the basin product manual.

PARTS LIST		
ITEM	DESCRIPTION	QTY
1	Water solenoid valves with cables. (Only when water valve pack has been ordered with basin)	2
2	Push fit 15mm street elbow (Not Supplied).	2
3	Wall fixing stud	4
4	Wall fixing washer	4
5	Wall fixing nut	4
6	Flange nut, for piezo tough button or IR sensor	2
7	Copper water tubes	2
8	Piezo touch button or IR sensor & wall tube	2
9	Waste pipe O ring	1
10	Waste pipe	1
11	Basin wall plate assembly	1

Important!
In order to maintain the anti-ligature and anti vandal properties of this product, it must be installed in line with the instructions provided.

© 2017 Copyright THIS DRAWING IS THE PROPERTY OF WALLGATE LIMITED AND IS ISSUED ON THE STRICT UNDERSTANDING THAT THE INFORMATION CONTAINED WILL NOT BE REPRODUCED, COPIED OR USED WITHOUT PRIOR AGREEMENT OF WALLGATE LTD.

	TITLE: BASIN ASSEMBLY DETAILS	MATERIAL:	Limits: (unless stated) ± 0.25mm (sheetmetal) ± 0.10mm (machined) ± 2.00mm (pattern) ± 5.00mm (moulded)	All dimensions in mm, All angles 90° (unless stated)
	Drg No: WHB-200-INS KIT	FINISH:	Scale: NTS	
Model/Client/Project:		A3		3rd